

**THE
WATER
PEOPLE**



HOME PRODUCTS

Countertop Water Filters
Crocks
Under Bench Filter Systems
Reverse Osmosis Purifiers
Shower and Bath filters
Baby and Children
Fridge Filters
e-Tap
Boiling Drinking water
Boiling and Ambient
Drinking Water
Boiling and Chilled
Drinking Water
Faucet Options

OFFICE PRODUCTS

Floor Standing Bubblers
Coolers
Chilled Water
e-Tap
Boiling Drinking water
Boiling and Ambient
Drinking Water
Boiling and Chilled
Drinking Water

TRAVEL PRODUCTS

INDUSTRIAL PRODUCTS

**InSinkErator
brings style to
your kitchen**



The Water People

22 High Street,
Glen Iris 3146

Ph: 03 9885 0222

Fax: 03 9885 6541

www.waterpeople.com.au

sales@waterpeople.com.au

Your Clear Choice

InSinkErator Indulge™ Contemporary Dispenser (near-boiling/chilled)

The InSinkErator Indulge™
Contemporary Dispenser
seamlessly blends form with
function.

Not only does it deliver near-
boiling 98°C water and chilled
drinking water on-the-fly, the
tap comes in chrome or brushed
chrome finish.

No kettles, no leads, no clutter, no
fuss....just 98°C near boiling and chilled
filtered water at the flick of a lever.

Features:

- Small office or domestic applications
- Timesaving, safe and convenient
- Ergonomic and easy to use lever tap
- Uses less energy than a 40 watt light bulb. You only heat as much water as you need
- Automatic shut-off hot water lever for safety
- Very compact hot water and chilled tanks fitted out of sight under your bench, the tap is all you see
- Includes filter system to enhance the taste and quality of the water

Do your bit for the environment, you only heat or chill as much water as you need, the taps are energy efficient and economical...saving you money every time they are used.

InSinkErator near boiling water tap is approximately 20% less expensive to operate than a standard kettle when heating water.

With their elegantly sleek lines, InSinkErator models don't just bring style to the kitchen; they bring a level of convenience that fits today's busy lifestyles.

Once you have one, you'll wonder how you ever did without it.



**THE
WATER
PEOPLE**



InSinkErator Indulge™ Contemporary Dispenser (near-boiling/chilled)

Hot Water Specifications:

- Flow rate - up to 100 cups of filtered steaming hot water at 98°C
- Capacity - 2.5 litre stainless steel tank
- Electrical - 220-240V, A.C. 1300 watts
- Weight - 5.5kg
- Warranty - 2 years in home warranty
- Dimensions - width 155mm x depth 171mm x height 279mm

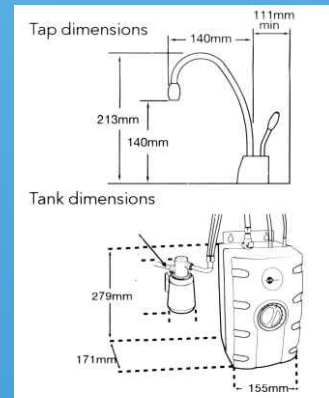

The Micro Chiller is:

- Silent running
- Provides 30 cups of chilled water instantly and up to 120 cups/hour
- Chills twice the volume of comparative under sink units with half chill down time
- 2/3 the height and 1/2 the width of comparative units - fits where other units can't
- Very cool running
- Energy efficient, environmentally friendly
- Australian designed and manufactured
- Comes with a full metal chassis and case as well as superior quality components



Micro Chiller Specifications

- Fully automatic operation
- Dimensions: width 280mm x depth 380mm x height 180mm
- Compressor: silent running, sealed compressor
- Automatic overload protection
- Condenser: Fan assisted convection cooled compressor/condenser
- Refrigeration: Non-toxic, non-flammable, ozone friendly R134A gas charged
- Temperature control: Capillary controlled factory pre-set thermostat
- Flow Rate: 15 litres/hour chilling capacity at 6°C based on 23°C ambient temperature
- Argon purged to ensure oxidation-free operation
- Capacity: Sealed stainless steel 1.5 litre tank
- Water connections: Inlet, outlet and drain - all 1/4" OD
- Insulation: Extra high density foam insulation for increased cooling efficiency enabling longer retention of lower temperatures
- Electrical: 240 volts, 1/12 hp, 50Hz, 0.8 amps, 2 metre 3 pin cable
- Weight: 13 kg

The Water People

22 High Street,

Glen Iris 3146

Ph: 03 9885 0222

Fax: 03 9885 6541

www.waterpeople.com.au

sales@waterpeople.com.au

Model NO.	Ltr per HOUR	H.P.	PHASE	GAS
UWC	15	1/12 th.	1/240	R.134A Env. Friendly

Warranty: 5 year warranty on sealed refrigeration system, return to base. Failure to comply with installation instructions supplied renders warranty null and void.

Your Clear Choice